

## OBSERVATIONS ON THE OXIDATION OF PROPANE

E. J. HARRIS AND A. EGERTON

*Department of Chemical Technology, Imperial College of Science and Technology,  
South Kensington, London, England*

*Received September 13, 1937*

As a result of an investigation carried out on the effect of antiknocks on the combustion of hydrocarbons, Egerton and Gates (2) concluded that a product of the oxidation of the aldehydes formed in the oxidation of the hydrocarbon assisted the autoxidation of the aldehyde stage of the combustion as well as the initial stage. The effect of inhibitors in delaying the combustion and Semenoff's work (7) on the oxidation of phosphorus led to the view that the combustion of hydrocarbons took place by a chain reaction mechanism (1). A study of the oxidation of pentane (6) helped to confirm this view.

Many investigations have been carried out in order to elucidate the nature of the mechanism of hydrocarbon combustion, but precise knowledge is still lacking. The observations on the oxidation of propane which follow, though they do not purport to do more than indicate some features of the combustion, add a few further facts to those already gathered, particularly by Pease in his studies of the oxidation of this hydrocarbon (5).

There is a general similarity in the combustion behavior of the straight-chain paraffin hydrocarbons and even of the olefins, which makes it probable that the propagation of the chain is effected in a similar way for different hydrocarbons, excepting that the mechanism in the higher ignition ranges is different in certain respects from that in the lower ranges.

Experiments have been made by the flow method and by the usual "static" method in which the gas mixture is maintained in a vessel at constant temperature. The surface conditions were varied, and small quantities of compounds which may be intermediates in the reactions were added in some of the experiments. The results are in general agreement with those obtained by Pease, but the analyses indicate that hydrogen peroxide is formed, as well as probably a small quantity of acetyl peroxide. Dihydroxymethyl peroxide is present in the condensate formed from formaldehyde and hydrogen peroxide. The amount of peroxide found depends on the surfaces to which the vapor is exposed.

## FLOW SYSTEM

A measured volume of gas (usually 600 cc.) was drawn at a constant rate through a reaction vessel (10 cm. long and 1.1 cm. in diameter) maintained at a constant temperature. A tube projected into a trap cooled to  $-40^{\circ}\text{C}$ . at the exit end of the reaction vessel. The gas then passed through a water scrubber into an aspirator; a second tube containing 2,4-dinitrophenylhydrazine sulfate could be used to test whether the absorption of the aldehyde was complete. The volume of gas and weight of condensate were ascertained.

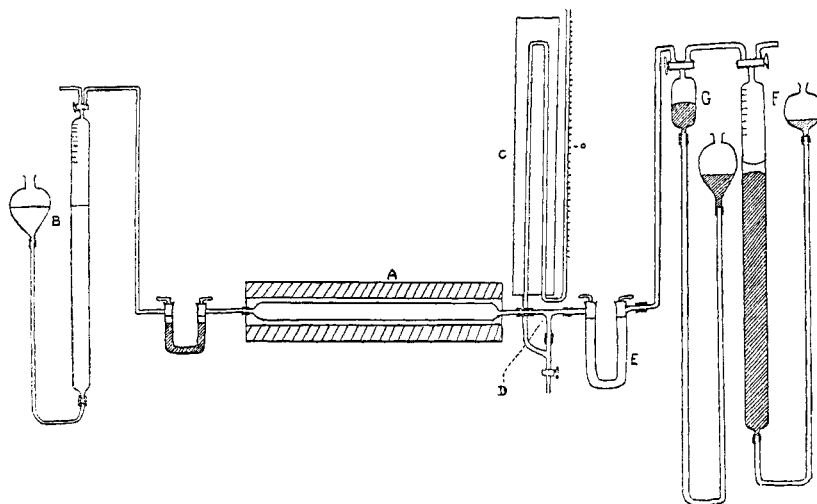

Fig. 1. Static system

## STATIC SYSTEM

The silica reaction vessel (A) (42 cm. long x 1.4 cm. in diameter) was connected at one end to a gas buret (B) and at the other to a manometer (C) and T-tube (D). The vessel could be connected either to a Hyvac pump or to a trap (E) for condensation of the liquid products, the gas being sucked into a second gas buret (F) by a Toepler pump arrangement (G). In order to obtain sufficient condensate six separate charges of gas were allowed to react to as nearly as possible the same extent as measured by the pressure change. Any aldehyde escaping the trap was collected in a small quantity of water in the gas buret (F). (See figure 1.)

Analyses were made, for peroxide by the iodine method using ammonium molybdate as catalyst, for total aldehydes by titrating the alkaline solution before and after oxidation with hydrogen peroxide solution, and for

formaldehyde by the mercuric chloride method after distillation to remove alcohols. Ethyl and methyl alcohols were determined in this distillate by oxidation by dichromate (8). The amount of higher alcohol was found to be small, so that little error was introduced if it was all assumed to be ethyl alcohol. The gas analysis was carried out in a Bone-Newitt apparatus with the addition of a tube of palladinized asbestos for the hydrogen determination.

## STATIC METHOD RESULTS

The results shown in table 1 were obtained using a clean silica vessel washed with hydrofluoric acid, and the same vessel after washing with saturated solutions of potassium chloride and of sodium chloride, respec-

TABLE 1  
Results obtained by static method  
For 1:1 mixture at 1 atm. initial pressure

| VESSEL  | TEMPERATURE IN °C. | USED                          |                | PRODUCTS IN GRAM-MOLES $\times 10^{-4}$ |      |                                |                |                 |      |      |                    |                                  |                  |
|---|--------------------|-------------------------------|----------------|---|------|--------------------------------|----------------|-----------------|------|------|--------------------|----------------------------------|------------------|
|   |                    | C <sub>3</sub> H <sub>8</sub> | O <sub>2</sub> | CO <sub>2</sub>                         | CO   | C <sub>2</sub> H <sub>5a</sub> | H <sub>2</sub> | CH <sub>4</sub> | HCHO | RCHO | CH <sub>3</sub> OH | C <sub>2</sub> H <sub>5</sub> OH | H <sub>2</sub> O |
| Silica (washed).....                          | 322                | 25                            | 47.4           | 5.3                                     | 28.2 | 2.8                            | 0.8            | 6.9             | 9.7  | 2.0  | 8.0                | 0                                | 41               |
| Silica (KCl).....                             | 351                | 21.8                          | 43.9           | 5.5                                     | 23   | 4                              | 0.7            | 4               | 2.6  | 3.4  | 6.4                | 0                                | 40.5             |
| Silica (KCl).....                             | 337                | 22.8                          | 46             | 7.8                                     | 25.2 | 4.6                            | 0.6            | 4.4             | 2.8  | 3.2  | 6.7                | 0                                | 39               |
| Silica (NaCl).....                            | 323-338            | 24.8                          | 45.7           | 7.7                                     | 19.6 | 3.6                            | 1.4            | 6.4             | 4.1  | 10.7 | 3.6                | 1.8                              | 46               |
| Silica (NaCl).....                            | 351                | 23.1                          | 42.3           | 6.0                                     | 22.6 | 5.3                            | 0.3            | 3.4             | 2.8  | 2.4  | 1.1                | 1.6                              | 39               |
| Silica (NaCl).....                            | 351                | 23.1                          | 42.5           | 5.7                                     | 21.4 | 4.6                            | 0.9            | 4.9             | 2.5  | 2.9  | 3.1                | 1.0                              | 41               |
| Silica (Fe <sub>2</sub> O <sub>3</sub> )..... | 355                | 12.4                          | 28.4           | 8.9                                     | 10.7 | 1.3                            | 0.3            | 4.0             | 0    | 2.3  | 0                  | 0                                | 25               |
| Graphite tube.....                            | 320                | 6.7                           | 20.5           | 11.5                                    | 5.2  | 0.6                            | 1.0            | 3.9             | 0    | 2.5  | 1.6                | 0                                | 9                |

tively. The reactions were allowed to go to completion. It was found that the induction period in successive experiments in the coated tubes became less, reaching a minimum, indicating that products which can initiate reaction are absorbed from the products of the previous run.

The temperature made no appreciable difference in the final composition of the products; it affected, however, the start and the time of the reaction, a higher temperature being needed to start the reaction in the case of the alkali-treated surfaces. The slower reactions were associated with a slightly higher amount of carbon dioxide, due probably to surface oxidation of aldehyde. There is throughout a close correspondence between the amount of oxygen used and the water formed.

The total aldehydes and alcohols were present in about the same amounts, along with nearly as much unsaturateds which were proved to contain both propylene and ethylene.

## FLOW EXPERIMENTS

The yields of products obtained are similar to those of the static experiments, provided the reaction is completed in the time of passage through the tube. The variation in contact time once the induction and reaction period has been exceeded has very little effect.

The peroxides, noted by Pease in the flow experiments, are not obtained in the static experiments, but they are obtained by the flow method using a clean acid-washed silica tube. The yield of peroxide is very susceptible to "poison"; it falls off after a few experiments but the surface can be cleaned again by acid wash. No peroxide is formed if soda glass reaction tubes are used, though Pyrex glass, as used by Pease, was found to behave similarly to quartz. If the hot gaseous products of reaction are led through a soft glass tube, the peroxides are immediately destroyed; so in the

TABLE 2

| PRODUCTS  | EXPERIMENT 1     | EXPERIMENT 2                |                                   |
|---|------------------|-----------------------------|-----------------------------------|
|   | Residue at 40°C. | Distillate, † of the volume | Residue, ‡ of the volume at 54°C. |
| CH <sub>3</sub> OH.....                         | Trace            | 0.300                       | Trace                             |
| HCHO.....                                       | 0.309            | 0.016                       | 0.045                             |
| CH <sub>3</sub> CHO.....                        | ?                | 0.076                       | 0.085                             |
| Oxygen for acid.....                            | ?                | 0.000                       | 0.037                             |
| Peroxide as H <sub>2</sub> O <sub>2</sub> ..... | 0.180            | 0.004                       | 0.022                             |
| Total.....                                      | 0.489            | 0.396                       | 0.193                             |
| H <sub>2</sub> O.....                           | 0.511            | 0.604                       | 0.807                             |

static experiments no peroxides were found, though they can be found if the whole reaction vessel is plunged into cold water before removal of the products. These results show that peroxides can be formed, but can only remain in the products if the surfaces to which the gases are exposed do not destroy them.

The peroxide-containing condensate from a prolonged flow experiment was fractionally distilled *in vacuo* at 2.2 cm. pressure. The distillate proved to be mainly aqueous methyl alcohol. Decomposition of the peroxides occurred during distillation; in experiment No. 1 the amount of peroxide estimated as hydrogen peroxide was approximately 10 per cent of the total liquid before distillation. On rapid distillation violent explosion occurred.

Table 2 gives the analysis per gram of the products. The quantity of formaldehyde and aldehydes includes the corresponding acids which may be present, though no acid was found in the distillate; the amounts

were determined by oxidation of the aldehydes after titration for acid, the oxygen equivalent to the acid being thus obtained. Peroxides are present other than peroxides which give rise to acid on decomposition. The acidity is appreciable only when large amounts of peroxide are formed and is not equivalent to the total peroxide.

The dihydroxyperoxide  $(\text{OH})\text{CH}_2\text{—O—O—CH}_2(\text{OH})$ , obtained by Lenger (4) during the oxidation of ethylene, is no doubt present. The ratio of formaldehyde to hydrogen peroxide in the residue in experiment No. 1 above is 0.0103 gram-mole/0.0053 gram-mole or 2/1. The behavior with potassium iodide is suggestive of this compound, but also alkaline decomposition of the peroxide condensate yielded a gas containing 80 per cent hydrogen and 20 per cent oxygen, the hydrogen being formed according to the reaction

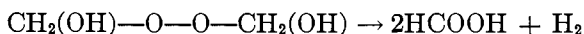

This peroxide, which is appreciably dissociated at room temperature, is formed from formaldehyde and hydrogen peroxide and probably does not exist in the uncondensed state. This is borne out by the observation that the hydrogen content of the vapors containing peroxide from the flow experiments is not increased by passage through a soda glass tube. The evidence points to hydrogen peroxide and acetyl peroxide being formed, both of which can decompose in the vapor state to give products which are not acid, though the latter may under certain circumstances give rise to acetic acid. There is no evidence for the formation of alkyl peroxides which on decomposition would give rise to further aldehyde or alcohol, unless in too small a quantity to be detected, but their transitory formation and decomposition is possible. (It is noteworthy, however, that in experiments in which ethyl hydrogen peroxide and acetyl peroxide were injected into an engine cylinder, they were collected again from a sample valve with less decomposition than in the case of hydrogen peroxide.)

The fact that no peroxide is formed from coated tubes is no evidence that peroxide-forming radicals are not present during the reaction; it merely means that the surface destroys such peroxide as is formed. The fact that there is little difference in the aldehydes formed in the coated tubes as compared with uncoated tubes indicates that hydrogen peroxide is the main peroxide existing in the vapor, but this is contrary to Pease's conclusion.

The figures for silica coated with iron oxide show an abnormal amount of carbon dioxide and no alcohols or formaldehyde. Experiments carried out in iron vessels will not be likely to give results similar to those found in glass or silica vessels, surface reaction of the products being enhanced. A graphite tube was also used with somewhat similar results.

Table 3 gives the amount of the various constituents of 1 g. of liquid condensate from flow and static experiments. The results indicate that except for a small variable amount of acids, the presence or not of peroxide makes little difference in the amounts of other products formed.

In the study of the effect of surfaces on the reaction, flow experiments are subject to the difficulty that if the induction period is long no appreciable reaction occurs, whereas if the flow is decreased or the temperature raised sufficiently to start the reaction, the reaction is quickly completed and it is not easy to get reliable analyses of the products before the com-

TABLE 3  
*Constituents of 1 g. of liquid condensate from flow and static experiments*

| Peroxide calculated as $\text{H}_2\text{O}_2$ | CONSTITUENTS IN GRAM-MOLES $\times 10^{-4}$ |  |                                 |   |   | PER CENT $\text{H}_2$ IN GAS | CONDITIONS                      | TEMPERATURE IN $^{\circ}\text{C}$ . |
|---|---|--|---------------------------------|---|---|------------------------------|---------------------------------|-------------------------------------|
|   | $\text{H}_2\text{O}$ by difference          | $\text{C}_2\text{H}_5\text{OH}$<br>$\text{C}_2\text{H}_6\text{OH}$ | $\text{HCHO}$<br>$\text{HCOOH}$ | $\text{C}_2\text{H}_3\text{CHO}$<br>$\text{C}_2\text{H}_3\text{COOH}$ | $\text{HCOOH}$<br>$\text{C}_2\text{H}_3\text{COOH}$ |                              |                                 |                                     |
| 22.7  | 300   | 54.6   | 38.4                            | 19.4  | 6.2   | 1.5                          | Flow system                     | 335                                 |
| 27.5  | 349   | 40.4   | 33                              | 21.4  | 9.8   | 2.3                          | Silica                          |                                     |
| 17.5  | (385)                                       | 26.3   | 31.5                            | 23.4  | 8.2   | 1.6                          |                                 |                                     |
|   | 375   | 44   | 30.7                            | 19.2  | 0   | 1.7                          | Static system                   | 328                                 |
|   | 331   | 64.6   | 29.9                            | 23.0  | (1.3)   | 1.0                          | Silica                          | 322                                 |
| 0.2   | 337   | 63.4   | 30.7                            | 31.4  | 0.7   | 0.8                          | Flow system                     | 344                                 |
|   | 346   | 62.2   | 35                              | 17.9  | 1.5   | 0.9                          | KCl on silica                   |                                     |
|   | 343   | 51   | 33.6                            | 27  | 0   | 1.2                          | KCl on glass                    |                                     |
|   | 332   | 57.0   | 23.8                            | 31.0  | 3.8   | 0.8                          | Static system                   | 337                                 |
|   | 346   | 54.6   | 21.2                            | 29.1  | 1.7   | 1.0                          | KCl on silica                   | 351                                 |
|   | 352   | 52.4   | 25.7                            | 20.2  | 3.7   | 1.8                          | Static system<br>NaCl on silica | 351                                 |

pletion of the reaction. The difficulty is greater because, when once started, the presence of reaction products tends to diminish the induction period.

In static experiments, on the other hand, although they provide means of obtaining analysis of the products at different stages of the reaction, the state of the surface is not the same throughout because of the changing composition of the gases.

Table 4 shows some analyses of products removed at predetermined pressures in a static experiment (silica bulb) with a 1:1 mixture at 1 atm. initial pressure: (a) The ratio for this 1:1 mixture of the gases  $\text{O}_2$  and  $\text{C}_3\text{H}_8$

used is approximately 2:1, as found by Pease. (b) The carbon monoxide, carbon dioxide, and methyl alcohol increase throughout, being formed as the result of decomposition of products formed by chain reactions. (c) The water, hydrogen, and aldehydes increase linearly with the amount of reaction, being products probably of chain reactions (their percentage remains constant except in the first stages). (d) The propylene and

TABLE 4

*Analyses of products removed at predetermined pressures in a static experiment*

| GAS USED |       | PRODUCTS IN GRAM-MOLES $\times 10^{-4}$ PER $10^{-3}$ GRAM-MOLES OF $C_3H_8$ USED |        |      |          |       |        |        |        |          |        | TEMPERATURE IN $^{\circ}C$ . |
|----------|-------|---|--------|------|----------|-------|--------|--------|--------|----------|--------|------------------------------|
| $C_3H_8$ | $O_2$ | $O_2$ (used)  | $CO_2$ | $CO$ | $C_3H_6$ | $H_2$ | $CH_4$ | $HCHO$ | $RCHO$ | $CH_3OH$ | $H_2O$ |                              |
| 8.1      | 13.3  | 16.4  | 1.0    | 5.3  | 2.7      | 0.6   | 5.7    | 0.7    | 1.0    | 0.8      | 17.9   | 320                          |
| 14.2     | 24.0  | 16.9  | 1.55   | 8.4  | 1.76     | 0.3   | 5.3    | 1.4    | 1.1    | 2.4      | 17.4   | 325                          |
| 22.4     | 39.8  | 17.8  | 1.34   | 9.4  | 1.83     | 0.3   | 1.1    | 0.9    | 1.2    | 2.0      | 17.4   | 340                          |
| 25.0     | 47.4  | 18.9  | 2.1    | 11.3 | 1.1      | 0.3   | 2.7    | 1.5    | 0.8    | 3.2      | 16.8   | 322                          |
| 25.7*    | 50.2  | 19.5  | 2.3    | 9.7  | 0.7      | 0.3   | 2.6    | 1.2    | 0.6    | 2.7      | 18.2   | 307                          |

\* Trace of acetaldehyde added to shorten induction period.

TABLE 5

*Effect of composition of the initial mixture at 1 atm. initial pressure on the composition of the products*

| INITIAL MIXTURE $C_3H_8:O_2$ | PRODUCTS IN GRAM-MOLES $\times 10^{-4}$ PER $10^{-3}$ GRAM-MOLES OF $C_3H_8$ USED |        |      |          |       |        |        |           |          |        | TEMPERATURE IN $^{\circ}C$ . |
|------------------------------|---|--------|------|----------|-------|--------|--------|-----------|----------|--------|------------------------------|
|                              | $O_2$ (used)  | $CO_2$ | $CO$ | $C_3H_6$ | $H_2$ | $CH_4$ | $HCHO$ | $CH_3CHO$ | $CH_3OH$ | $H_2O$ |                              |
| 1:1                          | 18.9  | 2.1    | 11.3 | 1.1      | 0.3   | 2.76   | 1.48   | 0.80      | 3.2      | 16.8   | 323                          |
|                              | 17.8  | 1.34   | 9.4  | 1.83     | 0.3   | 1.12   | 0.9    | 1.16      | 2.0      | 17.4   | 340                          |
|                              | 18.7  | 1.9    | 10.6 | 1.1      | 0.2   | 2.0    | 1.5    | 0.95      | 2.1      | 18.5   | 326                          |
| 2:1                          | 11.4  | 0.7    | 6.3  | 1.74     | 0.3   | 3.6    | 1.1    | 1.35      | 1.70     | 11.1   | 340                          |
|                              | 12.8  | 1.25   | 6.8  | 2.0      | 0.3   | 3.0    | 2.17   | 0.96      | 2.66     | 10.6   | 340                          |
| 4:1                          | 10.7  | 0.68   | 5.3  | 2.38     | 0.7   | 2.8    | 1.81   | 0.96      | 1.81     | 10.2   | 331                          |

methane appear to be formed early in the reaction. (e) The ratio of water formed to oxygen used is 1:1.

The experiments recorded in table 5 show the effect of the composition of the initial mixture at 1 atm. initial pressure on the composition of the products: (a) The ratio of water formed to oxygen used remains at about 1:1. (b) The ratio of oxygen to propane used, however, changes from 2:1 for the 1:1 initial mixture to 1:1 for the 4:1 initial mixture, the difference between the 1:1 and the 2:1 mixtures being much greater than

for the 2:1 and 4:1 mixtures. (c) The main difference between the 1:1 and the 2:1 mixtures is in the carbon monoxide and water formed.

These results indicate that the oxygen in the 1:1 mixture, owing to its higher concentration, provides an intermediate product which directly forms carbon monoxide and water, and about 6 moles more oxygen are consumed per 10 moles of propane reacting than for the 2:1 mixture (four oxygen atoms to carbon monoxide, seven to water, and about two to carbon dioxide). The excess of oxygen in the latter case and in the 4:1 mixture is insufficient to permit appreciable further reaction to carbon monoxide and water. It may be that reactions such as

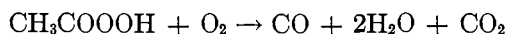

and

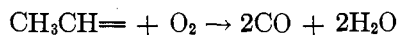

break the chains or destroy products, thus accounting for the fact that a large excess of oxygen tends to inhibit the slow reaction.

TABLE 6

| $\text{C}_3\text{H}_8$ USED | $\text{O}_2$ USED | PERCENTAGE<br>PRESSURE<br>INCREASE | PERCENTAGE<br>INCREASE IN<br>$\text{C}_3\text{H}_8$ USED | PERCENTAGE<br>INCREASE IN<br>$\text{O}_2$ USED |
|-----------------------------|-------------------|------------------------------------|--|--|
| 8.1                         | 13.3              | 4.5                                | 0.56   | 0.34   |
| 14.2                        | 24                | 7.9                                | 0.56   | 0.34   |
| 22.7                        | 41.1              | 17.3                               | 0.76   | 0.42   |
| 22.4                        | 39.8              | 17.2                               | 0.77   | 0.42   |
| 25                          | 47.4              | 19.8                               | 0.79   | 0.42   |
| 26.3                        | 49.2              | 21.45                              | 0.82   | 0.43   |

In the initial stages of the oxidation, the increase in the number of molecules caused by the reaction of one propane molecule is less than in the later stages, probably owing to dissociation of reaction products; pressure-time curves would need therefore to be corrected before direct deductions about the kinetics of the reaction could be made from them (see table 6).

The effect of the addition of certain individual reaction products to the initial 1:1 mixture at 300–340°C. was as follows: formaldehyde increased the induction period; acetaldehyde greatly decreased the induction period and increased the yield of methyl alcohol; propylene decreased the induction period; methyl alcohol had no effect.

These and other experiments which are being made at high and low



pressures by a variety of methods are part of an extensive investigation of hydrocarbon combustion which is being carried out in the Department of Chemical Technology at South Kensington. Until some of this other experimental work is more advanced, it is not proposed to discuss the above results in detail.

Several schemes to describe the behavior of hydrocarbons on oxidation have been suggested recently: e.g., Norrish's oxygen atom chain, Pease's "methoxyl radical" chain, the "peroxide radical" chain elaborated by Ubelohde, and a combination and extension of these presented still more recently by Lewis and von Elbe. It is not intended to elaborate any further schemes; a true interpretation will probably be found within the range of suggestions which have been put forward, but the experimental facts must be established before a satisfactory theory can be developed. The knocking characteristics of hydrocarbons early convinced one of the authors (3) that organic peroxides were playing a part in the oxidation of hydrocarbons. Particularly does that seem to be so now that those characteristics are linked by the work of Townend and his collaborators with the pressure ignition characteristics, but experimental elucidation of their exact function is still lacking. Experimental data are still needed to decide exactly what occurs under different conditions. It must also be pointed out that what happens in one part of the mixture undergoing reaction may be very different from the average behavior of the mixture, so that deductions from kinetics may be sometimes misleading; an exaggerated illustration of this is to be found in the pulsation phenomena of cool flames.

The oxidation of propane is characterized by (a) initiation by aldehyde, (b) early appearance of unsaturateds (propylene and ethylene), (c) formation of methyl alcohol and total aldehydes in approximately equivalent amounts, (d) destruction of peroxides at surfaces with apparently little change in the composition of the final products, and (e) formation of water approximately equivalent to the oxygen used.

A certain concentration of aldehyde or aldehyde peroxide is needed before reaction starts. It is possible that during this period the following reactions may take place:

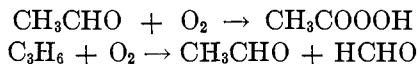

As both the formation and oxidation of the propylene depend on the oxygen concentration, the final amount obtained is approximately the same, unless the time during which the propylene is exposed to oxidation is exceptionally long, as table 7 shows.

When propylene is added to a 1:1 mixture of propane and oxygen,

the final concentration of unsaturateds obtained is approximately constant, as shown in table 8. The fact therefore that the concentration of propylene is greater at an early stage of the reaction and is not dependent on the propane concentration seems to indicate that its formation is associated with the products which initiate the reaction rather than with a direct process of dissociation of the propane. The total aldehydes formed in the reaction are approximately the same in amount as the methyl alcohol, when the oxygen concentration is low so that further oxidation is avoided. This indicates that both methyl alcohol and aldehyde are formed, probably

TABLE 7  
*Effect of oxygen concentration on the final amount of propylene*

| INITIAL RATIO OF PROPANE TO OXYGEN | UNSATURATEDS IN GRAM-MOLES $\times 10^{-4}$ | SURFACE CONDITION |
|------------------------------------|---|-------------------|
| 4:1                                | 4.2   | Silica            |
| 2:1                                | 4.4   | Silica            |
| 2:1                                | 4.8   | Silica            |
| 1:1                                | 4.1   | Silica            |
| 1:1                                | 4.3   | Silica            |
| 1:1                                | 4.6   | NaCl coated       |
| 1:1                                | 4.0   | KCl coated        |
| 1:1                                | 3.6   | NaCl coated       |
| 1:1                                | 4.6   | KCl coated        |

TABLE 8  
*Effect of addition of propylene upon final concentration of unsaturateds*

| PROPYLENE ADDED IN GRAM-MOLES $\times 10^{-4}$ | UNSATURATEDS IN FINAL GAS IN GRAM-MOLES $\times 10^{-4}$ |
|--|--|
| 0  | 4.4  |
| 3.6  | 3.9  |
| 7.6  | 4.3  |

as the products of a reaction chain. On further oxidation the acetaldehyde is burnt preferentially to formaldehyde, giving rise to cool flames; at higher temperatures the acetaldehyde probably dissociates to methane and carbon monoxide. At high pressures other alcohols are known to be formed, and it is probable that other reaction mechanisms come into play.

#### SUMMARY

1. Analyses of the products of the slow combustion of propane in oxygen by flow and static methods have been made.
2. Peroxides are found only when the surface does not destroy them too

fast to prevent their detection. In the vapor state hydrogen peroxide appears to be mainly present and dihydroxymethyl peroxide in the condensate.

3. Propylene is formed early in the reaction, possibly from the aldehydes which initiate the reaction.

4. Methyl alcohol and aldehydes appear to be formed by the same chain process.

## REFERENCES

- (1) EGERTON: *Nature* **122**, 516 (1928).
- (2) EGERTON AND GATES: *Aero Res. R. & M.*, No. 1079 (1926).
- (3) EGERTON AND GATES: *J. Inst. Petroleum Tech.* **13**, 244 (1927).
- (4) LENHER: *J. Am. Chem. Soc.* **53**, 3737 (1931).
- (5) PEASE: *J. Am. Chem. Soc.* **51**, 1839 (1929); **56**, 2034 (1934); **57**, 2296 (1935).
- (6) PIDGEON AND EGERTON: *J. Chem. Soc.* **1932**, 661.
- (7) SEMENOFF: *Z. Physik* **46**, 109 (1927).
- (8) HARRIS, E. J.: *Analyst* **62**, 729 (1937).